

 **POWERTEC®**

WB-PR16

Manual

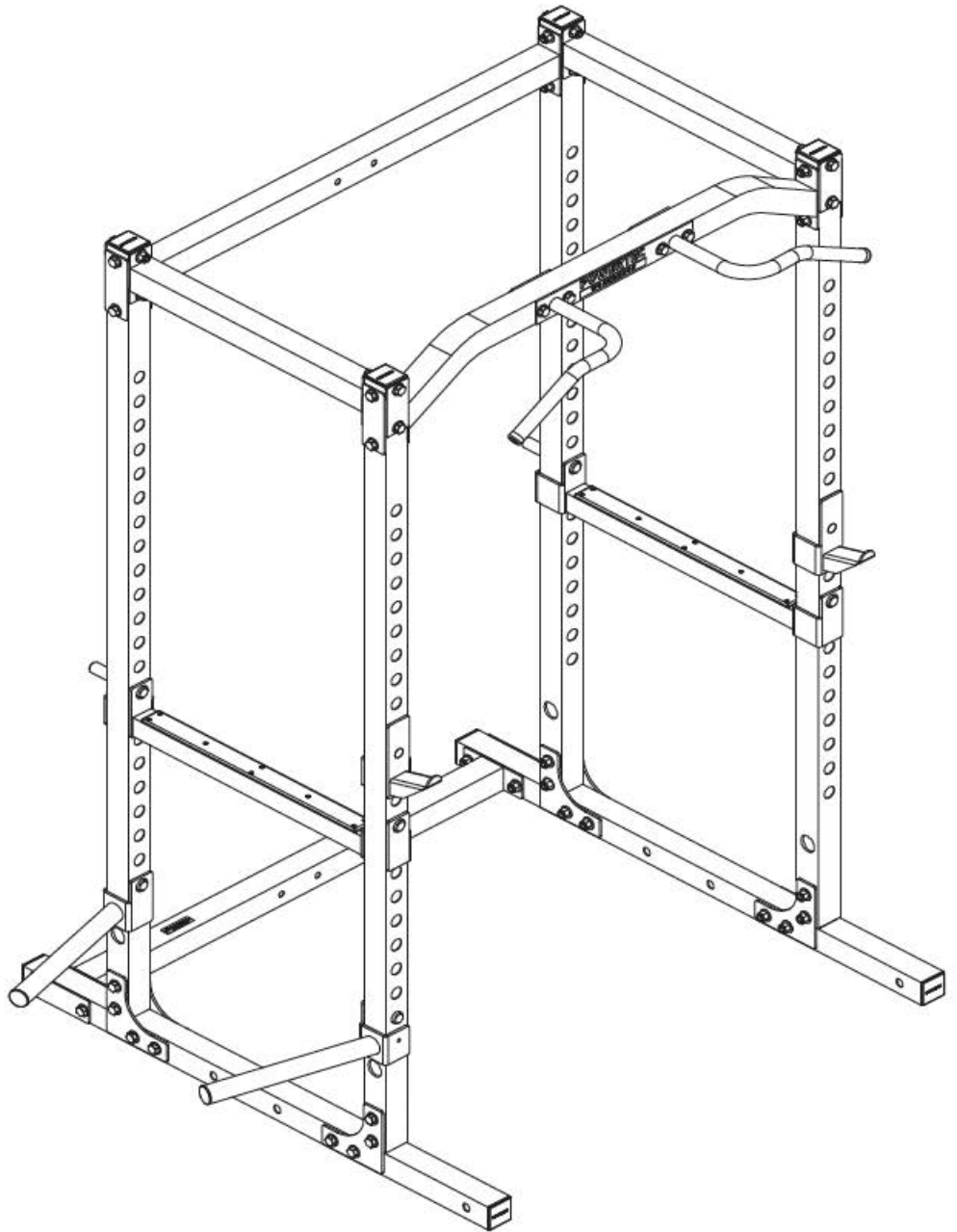

WORKBENCH POWER RACK

Thank you for purchasing your new Powertec equipment.
 To maximize the use of this Equipment, please take a moment to study, understand and familiarize with the assembly instructions and follow the sequence of steps as provided in the manual.

Because of our products unique features, this manual was created to provide you with information on how to assemble and properly maintain your equipment.

Table of Contents

Introduction and weight Capacities..... 2
 Safety Instructions, Warnings and Cautions 3
 Maintenance Tips..... 4
 Tools Required for Assembly..... 5
 Hardware List..... 6
 Parts List..... 7
 Exploded Diagram..... 8
 Assembly Steps..... 9-11
 Warranty Certificate..... 13
 Warranty Registration Card..... 14

WB-PR16 Power Rack

Specifications

- L 50.8"
- W 66"
- H 84"

Weight Capacity

Racking Section	1000 lbs.
Chin Up Bars	400 lbs. of Body Weight.
Dip Bars	400 lbs. of Body Weight.

The following exercises can be performed on the WB-PR16 Power Rack

Dips	Hanging Leg Raises	Hanging Leg Twists
Chin Ups	Push Ups	Horizontal Pull Ups

Customize your Power Rack and multiply your exercises by adding the following recommended accessories.

WB-UB16	Utility Workbench	WB-LTO16	Lat Tower Option
WB-UB16-CN	Utility Workbench Connector	WB-PR16-EXA	Power Rack 5" Extension
WB-PR16-SUPA	Step Up Plate Attachment	WB-PR16-WHA	Weight Plate Storage Horn
WB-PR16-RRA	Rope - Strength Bands Attachment	WB-PR16-MGBA	Multi-Grip Pull-Up Bar
OP-255-B	Olympic Plate Set 255 lbs. Plates	WB-PR16-BLA	Barbell / Barbell Landmine
OS-300-B	Olympic Plate Set 300 lbs. Plates + Olympic Bar		

SAFETY INSTRUCTIONS, WARNINGS AND CAUTIONS



It is recommended that users of this equipment receive a thorough medical exam before commencing any exercise program. This is especially important if you have never Exercised and or are over the age of 35, are pregnant or suffer from any health issues.

Read All Warnings and Cautions on this Manual and on the Product

This product should only be used after a thorough review of the Owner's Manual.

Keep children away from the product when in use.

Set up and operate the product on a solid level surface.

Do not set up the product on loose rugs or uneven surfaces.

Make sure adequate space is available to exercise and move around the product.

Inspect product before and after each use, inspect for worn out or loose parts, repair or replace as needed.

This equipment meets industry safety standards for stability when used for the intended exercise. Do not allow straps, resistance bands or other means to be attached to the framework of this equipment to perform stretching or body weight exercises as it can result to equipment instability and lead to serious injuries.

Always choose a workout that best fits your needs, physical strength and flexibility Levels, know your limits and your product limits and train within them.

Always wear proper footwear with nonskid rubber soles such, running, walking or Cross training shoes that fit well and provide support.

Do not exercise bare foot or in socks.

Always use common sense when exercising.

POWERTEC[®]



MAINTENANCE



The safety and performance of this product can be maintained only if it is examined regularly for damage and normal wear. Examine the equipment before each use for damage and wear. Replace damaged and worn components immediately or put the equipment out of use until repaired.

Inspect Daily / Before Each Use!

Inspect system. Make sure it is in good condition and operates smoothly. If you find damage, **DO NOT USE**. Contact your authorized Powertec dealer or Powertec Customer Service Center for assistance.

Inspect Daily / After Each Use!

Clean system with a clean, dry cloth. Use a mild detergent or spray on upholstery. Do Not use cleansers containing enzymes.

Inspect Weekly!

Clean your system fully with a clean and ammonia based cleaner. Touch up any scratches with touch-up paint to prevent rust, if necessary.

Inspect Monthly!

Examine the frame for signs of cracking or permanent bending. Do not use the equipment if you see this. Contact Powertec Customer Service Immediately. If you have any questions on the correct use or maintenance of this equipment, call your authorized distributor or Powertec Customer Service at 800-250-6665

Our Customer Service Mission:

“Committed to Stronger Lives”

By providing friendly and understanding service.

Tools Required for Assembly



M6 Allen Wrench



Wrenches
13 mm = 1/2"
19 mm = 3/4"
21 mm = 13/16"



8" Adjustable Wrench

HARDWARE LIST

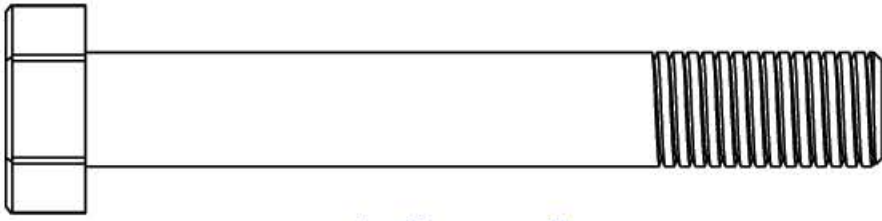

NO. 19 1/2"x3.5" 40 PCS

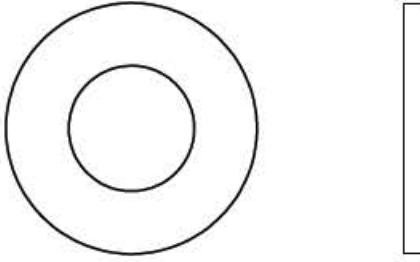

NO. 18 1/2" 80 PCS

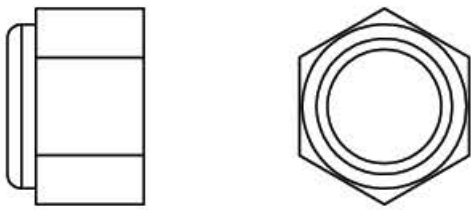

NO. 20 1/2" 40 PCS

WB-PR16

WORKBENCH POWER RACK

PART LIST



Part#	Description	QTY
1	Lower Linkage Tube	1
2	Base Tube	2
3	Upright	4
4	Horizontal Tube	1
5	Linkage Tube	2
6	Top Linkage Tube	1
7	Weight Support Tube	1
8	Weight Support Tube	1
9	Pull-Up Bar	1
10	Linkage Plate	2
11	Dip Bar	1
12	Dip Bar	1
13	Weight Support Tube	1
14	Weight Support Tube	1
15	Linkage Plate	6
16	Linkage Plate	8
17	Linkage Plate	4
18	Washer 1/2"	80
19	Hex Bolt 1/2"X3 1/2"	40
20	Nylon Nut 1/2"	40

WB-PR16

WORKBENCH POWER RACK

EXPLODED DIAGRAM

POWERTEC®

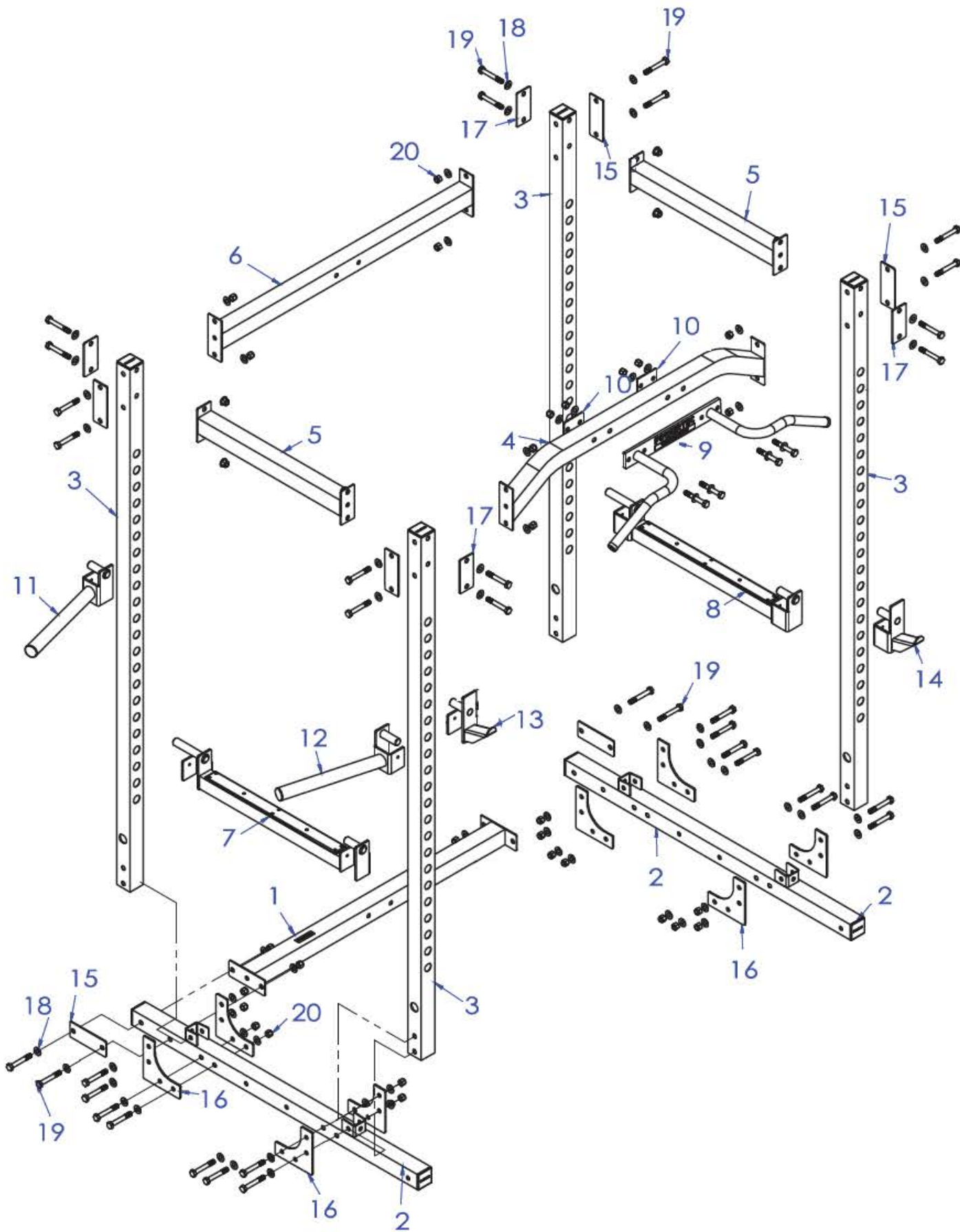

Remarks: All unmarked washers are (18)
and all unmarked Nylon Nuts are (20)

WB-PR16

WORKBENCH POWER RACK

ASSEMBLY ONE

Step 1

Attach Lower Linkage Tube No. 1 to Base Tubes No. 2 Use Linkage Plates No. 15 and No. 16 Secure with Bolts No. 19, Washers No. 18 and Nuts No. 20

Step 2

Install Up-Rights No. 3 to Base Tubes No. 2 using Linkage Plates No. 16 Bolts No. 19, Washers No. 18 and Nuts No. 20

Do Not Fully Tighten Hardware Until Assembly is Finished.

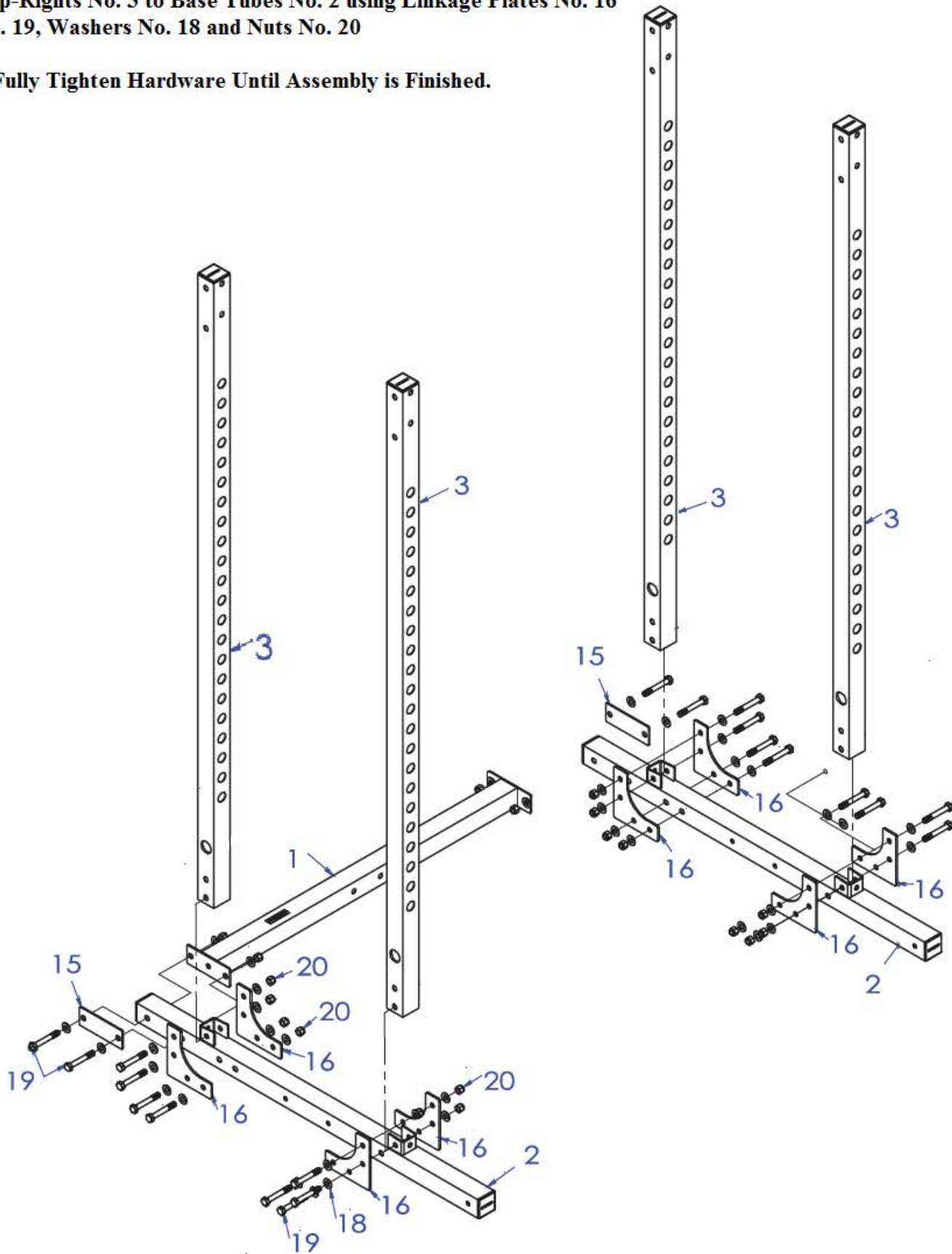

POWERTEC[®]

WB-PR16

WORKBENCH POWER RACK

ASSEMBLY TWO

POWERTEC[®]

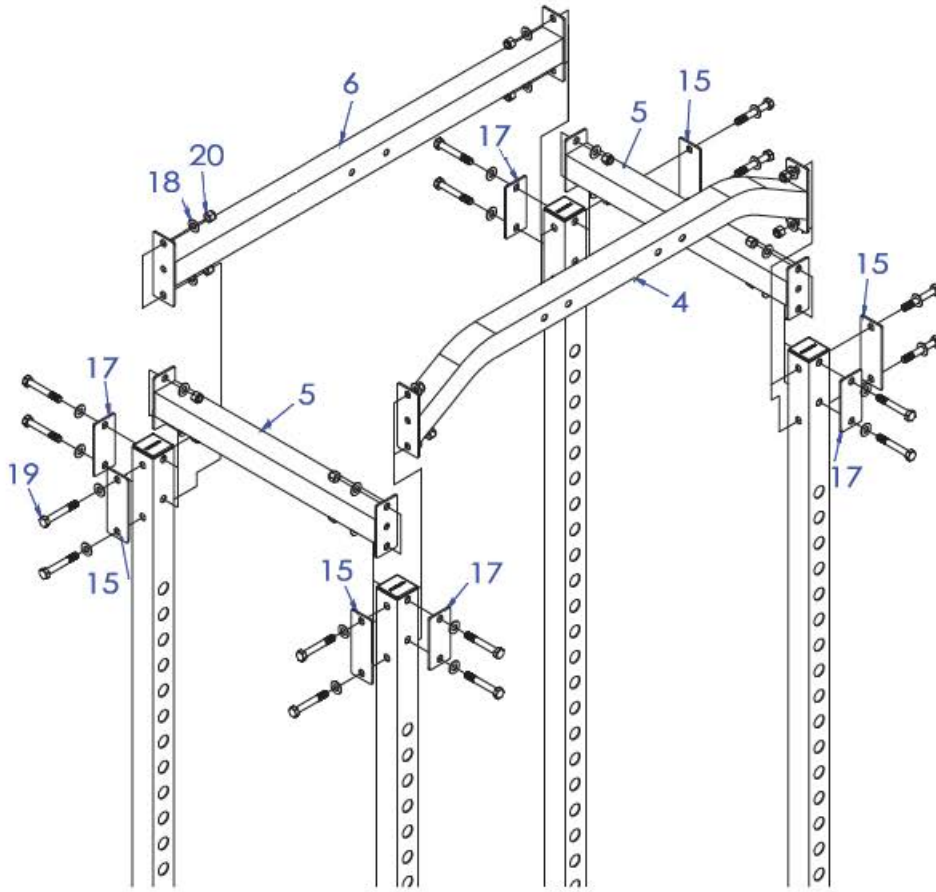

Step 1

Attach Top Linkage Tube No. 6 to Up-Right No. 3
make sure to include Linkage Plates No. 15 at
each end and secure them with Bolts No. 19,
Washers No. 18 and Nuts No. 20

Step 2

Attach Linkage Tube No 5 to each Up-Rights No. 3
make sure to include Linkage Plates No. 17 and
include Bolts No. 19, Washers No. 18 and Nuts No. 20

Step 3

Attach Horizontal Tube No. 4 to Up-Rights No. 3
make sure to include Linkage Plates No. 15 and include
Bolts No. 19, Washers No. 18 and Nuts No. 20

Do Not Fully Tighten Until Assembly Has Been Completed!

WB-PR16

WORKBENCH POWER RACK

ASSEMBLY THREE

POWERTEC[®]

Step 1

Install Pull UP Bars No. 9 to Horizontal Tube No. 4
Use Linkage Plates No. 10, Bolts No. 19, Washers
No. 18 and Nuts No. 20.

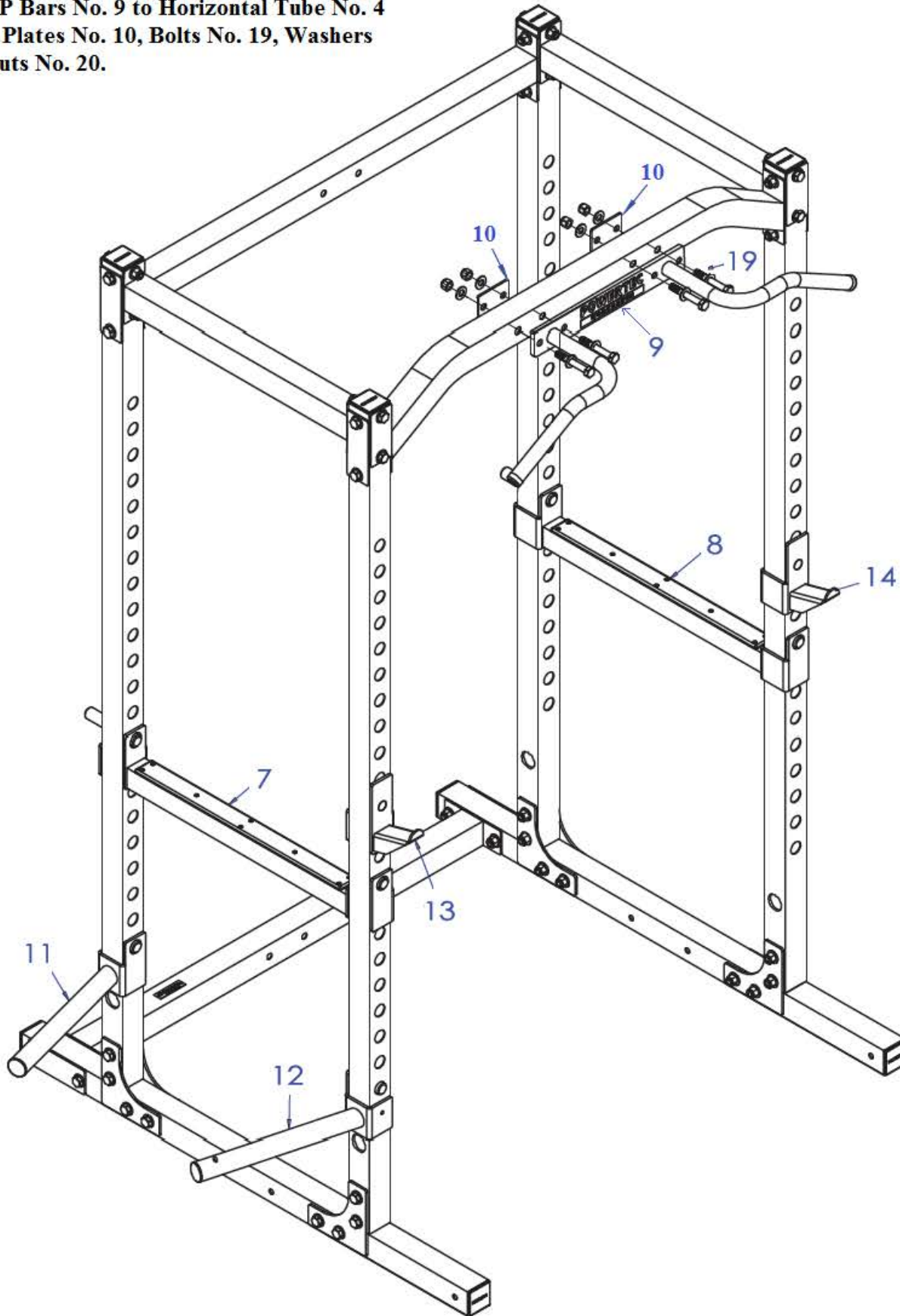

Weight Support Tubes No. 7, No. 8 are the Spotters and can be adjusted to different height settings as needed.

Weight Support Tubes No. 13 and No. 14 are your Safety Catches or J Hooks and can be positioned on the inside or the outside of the Power Rack and adjusted as needed.

Dip Bars No. 11 and No. 12 can be positioned on the inside or the outside of the Power Rack and adjusted as needed.

WB-PR16

WORKBENCH POWER RACK

WB-PR16

EXERCISES

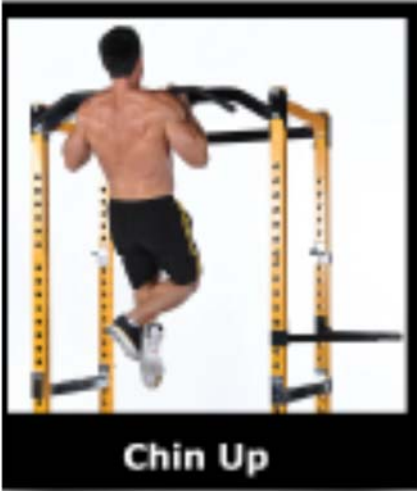

Chin Ups

Grip the Bar at the top of the Power Rack.
Pull yourself up until your chin reaches
The height of the bar or as far as you can.
Pause briefly before returning to the starting position.



Abdominal Hanging Leg Raises

Grip the bar at the top of the Power Rack.
Keep your leg straight and raise your legs in front
Of you until your feet are at waist level or as high
As you can.
Pause briefly before returning to the starting position.

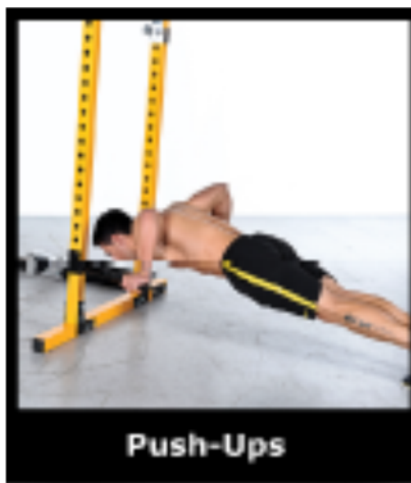

Push Ups

Adjust the Dip Bars, placing them one foot from the
ground. Grab the Dip Bars with your arms fully extended.
Do Not Lock Elbows, and extend your body facing the floor
Keep your legs, back and neck straight and aligned. Curl your
Toes up and allow the weight to rest on the balls of your feet.
Lower yourself, bending the elbow, until elbows are at a 90°
degree angle.
Pause briefly before returning to the starting position.



Dips

Face the machine and place yourself in between
The Dip Bars. Grip the Dip Bars and keep arms
fully extended, Do Not Lock Your Elbows.
As you bend your knees, lifting your feet off the
ground and crossing your ankles behind you.

Slowly lower yourself until your chest is almost
At the level of the Dip Bars.
Do Not Dip Too Far Down.
Pause briefly before returning to the starting position.